



Taps for steels from 25~45 HRC

H-TAP

Volume 2



KEY FEATURES: H-TAP



1 For steels 25~45 HRC

2 Also for tool steels

3 Steam oxide treatment:
improved lubricity

4 Powder metal:
high wear resistance

H-SFT

Threading | Cutting taps | Metric



- Powder metal low spiral-fluted cutting tap for blind holes
- Steam oxide treatment
- For hardened steels up to 45 HRC

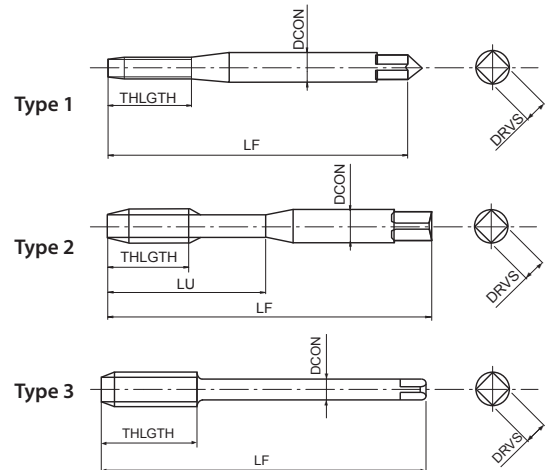

| | | | | | | | |
|----------|----------|----------|----------|----------|----------|-----|-------|
| P | K | S | S | H | H | | |
| 7-12 | 7-12 | 7-12 | 3-5 | 1-3 | 4-8 | 4-8 | m/min |

| | | | | | | | |
|----------|-----------|-----------|------------|-----------------|------------|----------------|----------------|
| M | PM | OX | 15° | ISO 2 6H | C/3 | DIN 371 | DIN 376 |
|----------|-----------|-----------|------------|-----------------|------------|----------------|----------------|

| EDP | TD | TP | LF | THLGTH | LU | DCON | DRVS | NOF | Type | DIN |
|----------|-----|------|-----|--------|----|------|------|-----|------|-----|
| 83212560 | 2 | 0,4 | 45 | - | 8 | 2,8 | 2,1 | 2 | 1 | 371 |
| 83213360 | 2,5 | 0,45 | 50 | - | 9 | 2,8 | 2,1 | 2 | 1 | 371 |
| 83213860 | 3 | 0,5 | 56 | - | 18 | 3,5 | 2,7 | 3 | 2 | 371 |
| 83214460 | 4 | 0,7 | 63 | - | 21 | 4,5 | 3,4 | 3 | 2 | 371 |
| 83214960 | 5 | 0,8 | 70 | - | 25 | 6 | 4,9 | 3 | 2 | 371 |
| 83215560 | 6 | 1 | 80 | - | 30 | 6 | 4,9 | 3 | 2 | 371 |
| 83216160 | 8 | 1,25 | 90 | - | 35 | 8 | 6,2 | 3 | 2 | 371 |
| 83216960 | 10 | 1,5 | 100 | - | 39 | 10 | 8 | 3 | 2 | 371 |
| 83317960 | 12 | 1,75 | 110 | 18 | - | 9 | 7 | 3 | 3 | 376 |
| 83319160 | 14 | 2 | 110 | 20 | - | 11 | 9 | 3 | 3 | 376 |
| 83320260 | 16 | 2 | 110 | 20 | - | 12 | 9 | 3 | 3 | 376 |
| 83321460 | 18 | 2,5 | 125 | 25 | - | 14 | 11 | 4 | 3 | 376 |
| 83322860 | 20 | 2,5 | 140 | 25 | - | 16 | 12 | 4 | 3 | 376 |

Threading | Cutting taps

Metric

H-POT

Threading | Cutting taps | Metric



- Powder metal spiral-point cutting tap for through holes
- Steam oxide treatment
- For hardened steels up to 45 HRC

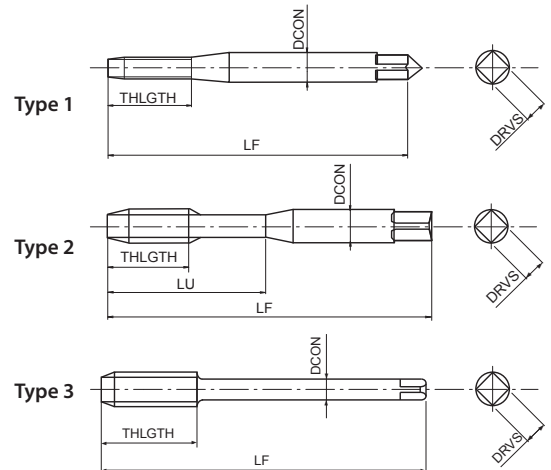

| | | | | | | |
|-----------------------|-----------------|----------------|----------------|-----------------------|-----------------------|-------|
| P C ≥ 0,45% | K GGG | S Ti | S Ni | H 25-35 HRC | H 35-45 HRC | |
| 8-13 | 10-15 | 4-6 | 2-4 | 6-10 | 6-10 | m/min |

| | | | | | | |
|----------|-----------|-----------|-----------------|------------|----------------|----------------|
| M | PM | OX | ISO 2 6H | B/5 | DIN 371 | DIN 376 |
|----------|-----------|-----------|-----------------|------------|----------------|----------------|

| EDP | TD | TP | LF | THLGTH | LU | DCON | DRVS | NOF | Type | DIN |
|----------|-----|------|-----|--------|----|------|------|-----|------|-----|
| 88412560 | 2 | 0,4 | 45 | 8 | - | 2,8 | 2,1 | 2 | 1 | 371 |
| 88413360 | 2,5 | 0,45 | 50 | 9 | - | 2,8 | 2,1 | 2 | 1 | 371 |
| 88413860 | 3 | 0,5 | 56 | - | 18 | 3,5 | 2,7 | 3 | 2 | 371 |
| 88414460 | 4 | 0,7 | 63 | - | 21 | 4,5 | 3,4 | 3 | 2 | 371 |
| 88414960 | 5 | 0,8 | 70 | - | 25 | 6 | 4,9 | 3 | 2 | 371 |
| 88415560 | 6 | 1 | 80 | - | 30 | 6 | 4,9 | 3 | 2 | 371 |
| 88416160 | 8 | 1,25 | 90 | - | 35 | 8 | 6,2 | 3 | 2 | 371 |
| 88416960 | 10 | 1,5 | 100 | - | 39 | 10 | 8 | 3 | 2 | 371 |
| 88517960 | 12 | 1,75 | 110 | 28 | - | 9 | 7 | 3 | 3 | 376 |
| 88519160 | 14 | 2 | 110 | 30 | - | 11 | 9 | 3 | 3 | 376 |
| 88520260 | 16 | 2 | 110 | 32 | - | 12 | 9 | 4 | 3 | 376 |
| 88521460 | 18 | 2,5 | 125 | 34 | - | 14 | 11 | 4 | 3 | 376 |
| 88522860 | 20 | 2,5 | 140 | 34 | - | 16 | 12 | 4 | 3 | 376 |

Threading | Cutting taps

Metric

H-POT

Threading | Cutting taps | UNJF

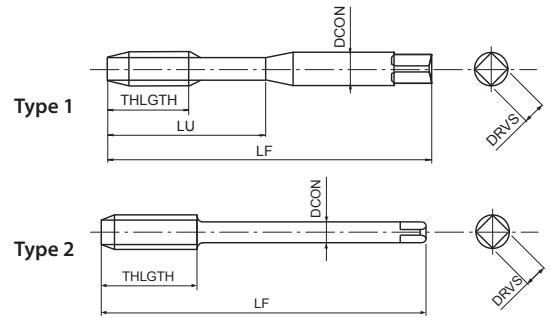

- Powder metal spiral-point cutting tap for through holes
- Steam oxide treatment
- For hardened steels up to 45 HRC

| | | | | | | |
|--------------------|--------------|-------------|-------------|--------------------|--------------------|-------|
| P C ≥ 0,45% | K GGG | S Ti | S Ni | H 25-35 HRC | H 35-45 HRC | |
| 8-13 | 10-15 | 4-6 | 2-4 | 6-10 | 6-10 | m/min |

| | | | | | | |
|-------------|-----------|-----------|----------------|-----|------------|------------|
| UNJF | PM | OX | ANSI 3B | B/5 | DIN 2184-1 | DIN 2184-1 |
|-------------|-----------|-----------|----------------|-----|------------|------------|

| EDP | TD | TP | LF | THLGTH | LU | DCON | DRVS | NOF | Type | DIN |
|----------|------|----|-----|--------|----|------|------|-----|------|--------|
| 48010467 | 10 | 32 | 70 | - | 25 | 6 | 4,9 | 3 | 1 | 2184-1 |
| 48010472 | 1/4 | 28 | 80 | - | 30 | 7 | 5,5 | 3 | 1 | 2184-1 |
| 48010476 | 5/16 | 24 | 90 | - | 35 | 8 | 6,2 | 3 | 1 | 2184-1 |
| 48010481 | 3/8 | 24 | 90 | - | 35 | 9 | 7 | 3 | 1 | 2184-1 |
| 48010486 | 7/16 | 20 | 100 | 20 | - | 8 | 6,2 | 3 | 2 | 2184-1 |
| 48010491 | 1/2 | 20 | 100 | 22 | - | 9 | 7 | 3 | 2 | 2184-1 |

Threading | Cutting taps

UNJF





www.osgeurope.com





shaping your dreams

OSG EUROPE LOGISTICS

Avenue Lavoisier 1
B-1300 Z.I. Wavre - Nord - Belgium
Tel: +32 10 23 05 07
Fax: +32 10 23 05 51
info@osgeurope.com

OSG BELUX

Avenue Lavoisier 1
B-1300 Z.I. Wavre - Nord - Belgium
Tel: +32 10 23 05 11
Fax: +32 10 23 05 31
info@osg-belgium.com

OSG FRANCE

Parc Icade, Paris Nord 2
Immeuble "Le Rimbaud"
22 Avenue des Nations
CS66191 - 93420 Villepinte - France
Tel: +33 1 49 90 10 10
Fax: +33 1 49 90 10 15
sales@osg-france.com

OSG NETHERLANDS

Bedrijfsweg 5 - 3481 MG Harmelen
Tel: +31 348 44 2764
Fax: +31 348 44 2144
info@osg-nl.com

OSG UK

Kelsey Close, Attleborough Fields Ind Est,
CV11 6RS, Nuneaton, United Kingdom.
Tel: +44 1827 720 013
uk_sales@osg-uk.com

CZECH, SLOVAKIA, HUNGARY

OSG Europe Logistics S.A.
Slovakia organizacna zlozka
Racianská 22/A, SK-83102 Bratislava
Slovakia
Tel. +421 24 32 91 295
Orders-osgsvk@osgeurope.com

OSG POLAND Sp. z.o.o.

Spółdzielcza 57
05-074 Halinów - Poland
Tel: +22 760 82 71
Fax: +22 760 82 71
osg@osg-poland.com

OSG GERMANY

Karl-Ehmann-Str. 25
D - 73037 Göppingen - Germany
Tel: +49 7161 6064 - 0
Fax: +49 7161 6064 - 444
info@osg-germany.de

OSG SCANDINAVIA

(For Scandinavian countries)
Langebjergvaenget 16
4000 Roskilde - Denmark
Tel: +45 46 75 65 55
Fax: +45 46 75 67 00
osg@osg-scandinavia.com

SWEDEN

Branch office of OSG SCANDINAVIA
Singelgatan 7
212 28 Malmö - Sweden
Tel: +46 40 41 22 55
osg@osg-scandinavia.com

OSG IBERICA

Bekolarra 4
E - 01010 Vitoria-Gasteiz - Spain
Tel: +34 945 242 400
Fax: +34 945 228 883
osg.iberica@osg-ib.com

RUSSIA

Butlerova street, 17B, office 5069
117342 Moscow - Russia
Tel: +7 (495) 150 41 54
info@osg-russia.com

OSG TURKEY

Rami Kişla Cad.No:56 Eyüp
Istanbul 34056 - Turkey
Tel+90 212 565 24 00
Fax: +90 212 565 44 00
info@osg-turkey.com

ROMSAN INTERNATIONAL CO. SRL

Reprezentant Exclusiv OSG
25C, Bucuresti-Magurele Street
051431 Bucuresti - România
Tel: +40 21 322 07 47
Fax: +40 21 321 56 00
romsan.int@romsan.ro

AUSTRIA

Branch office of OSG GERMANY
Messestraße 11
A-6850 Dornbirn
Tel: +49 7161 6064-0
Fax: +49 7161 6064-444
info@osg-germany.de

OSG ITALIA

Via Ferrero, 65 A/B3
I - 10098 Rivoli - Italy
Tel: +39 0117705211
Fax: +39 0117705215
info@osg-italia.it

Vischer & Bolli AG

Machining and Workholding
Im Schossacher 17
CH-8600 Dübendorf
T +41 44 802 15 15
F +41 44 802 15 95
info@vb-tools.com

OSG EUROPE LOGISTICS S.A.

01/2022 - All rights reserved. © OSG Europe 2022

The contents of this catalogue are provided to you for viewing only. They are not intended for reproduction either in part or in whole in this or other medium. They cannot be copied, used to create derivation work or used for any reason, by means without the express, written permission of the copyright owner. If prices are stated, they are netto unit-prices and any eventual tax(es) have to be added. The company is not responsible for any printing error in technical, price and/or any other data.

Tool specifications subject to change without notice.

www.osgeurope.com

